

## EFFECT OF LIGHT-CURING UNIT AND ADHESIVE SYSTEM ON MARGINAL ADAPTATION OF CLASS V COMPOSITE RESTORATIONS

Denise S. Maia-Casseli<sup>1</sup>, André L. Faria-e-Silva<sup>2</sup>, Andréa N. Cavalcanti<sup>3</sup>,  
Eliene A.O.N. Romani<sup>4</sup>, Luis R.M. Martins<sup>4</sup>

<sup>1</sup> Department of Dentistry, Campus of Sobral, Federal University of Ceará, Sobral, CE, Brazil.

<sup>2</sup> Department of Dentistry, Federal University of Sergipe, Aracaju, SE, Brazil.

<sup>3</sup> Department of Dentistry, Bahiana School of Medicine and Public Health, Salvador, BA, Brazil.

<sup>4</sup> Department of Restorative Dentistry, Piracicaba Dental School, State University of Campinas, Piracicaba, SP, Brazil.

### ABSTRACT

The aim of this study was to evaluate the effect of light-curing units (LED or halogen) on the marginal adaptation of composite restorations performed with etch-and-rinse and self-etching adhesive. Class V cavities were prepared on bovine teeth with the gingival margin on dentin and the incisal margin on enamel. The cavities were restored with a micro-hybrid resin composite using an etch-and-rinse (Single Bond 2 - SB) or a self-etching adhesive (Clearfil SE Bond - CL). The light-activations were performed using halogen lamp (Optilux 501 - QTH) or second-generation light-emitting diode (Ratii-Cal - LED) (n=10). After finishing and polishing the restorations, epoxy replicas were prepared. The marginal adaptation was analyzed under scanning electronic microscopy with 500x of magnification. The greatest gap width at each margin was

recorded. Data were submitted to Mann-Whitney and Wilcoxon tests ( $\alpha = 0.05$ ). SB and CL showed similar behavior of enamel margins when the light-activations were performed with QTH. The same was observed for dentin margins with LED. When the LED was used, higher gap measurements at enamel margins were observed with CL, while higher gap values in dentin were observed for SB within QTH. No significant difference between substrates was found when CL was used. However, SB had significantly higher gap measurements in dentin. The light-curing unit seems to affect the marginal adaptation of resin composite restorations. However, this effect was dependent on the adhesive and the location of the margin.

Keywords: adhesives; composite resins; dental marginal adaptation; curing lights, dental.

## EFEITO DO APARELHO FOTOPOLIMERIZADOR E DO SISTEMA ADESIVO NA ADAPTAÇÃO MARGINAL DE RESTAURAÇÕES CLASSE V DE COMPÓSITO

### RESUMO

O objetivo deste estudo foi avaliar o efeito do aparelho fotopolimerizador (LED ou halogen) na adaptação marginal de restaurações de compósito realizadas com adesivo convencional ou auto-condicionante. Cavidades classe V foram preparadas em dentes bovinos com margem gengival em dentina e incisal em esmalte. As cavidades foram restauradas com uma resina composta micro-híbrida usando um adesivo convencional (Single Bond 2 - SB) ou um auto-condicionante (Clearfil SE Bond - CL). As fotoativações foram realizadas usando uma lâmpada halógena (Optilux 501 - QTH) ou um diodo emissor de luz de segunda geração (Ratii-Cal - LED) (n=10). Após acabamento e polimento das restaurações, réplicas em resina epóxica foram preparadas. A adaptação marginal foram analisadas sob microscopia eletrônica de varredura com 500x de aumento. A maior largura da fenda em cada margem foi registrada. Os dados

foram submetidos aos testes de Mann-Whitney e Wilcoxon ( $\alpha = 0.05$ ). SB e CL mostraram comportamento similar nas margens em esmalte quando as fotoativações foram realizadas com QTH. O mesmo foi observado nas margens em dentina com LED. Quando o LED foi usado, maiores medidas de fenda em margens em esmalte foram observadas com CL, enquanto maiores valores de fendas foram observados para SB com QTH. Diferenças significativas entre os substratos não foram observadas quando CL foi usado. Entretanto, SB apresentou significativamente maiores medidas de fenda em dentina. O aparelho fotopolimerizador parece ter efeito na adaptação marginal de restaurações de resina composta. Entretanto, este efeito foi dependente do adesivo e da localização da margem.

Palavras-chave: adesivos, resina composta, adaptação marginal dental, fotopolimerizadores, dental.

## INTRODUCTION

Despite the improvements in restorative materials in recent decades, the marginal integrity of a restoration remains a challenge for dentistry. Poor marginal adaptation may produce marginal discoloration, postoperative sensibility and secondary caries.<sup>1</sup> These are the most frequent reasons for replacing or repairing an adhesive restoration<sup>2,3</sup>. The marginal failure of composite resin restorations is related mainly to the stress generated by the polymerization shrinkage of composites<sup>4</sup> and to the quality of bonding to dental structure<sup>5</sup>.

Resin-based materials contain monomers (di)methacrylates that polymerize under irradiation with visible light<sup>6</sup>. Shrinkage of the composite is a result of the reduction in intermolecular distance between monomer units during the polymerization process<sup>7</sup>. Thus, a higher degree of conversion is also related to an increase in polymerization shrinkage and consequently, in the stress generated by shrinkage<sup>7,8</sup>. If the stress exceeds the bond strength between the dental substrate and the adhesive system, a contraction gap will be formed<sup>9,10</sup>, jeopardizing the longevity of the restoration.

For many years, quartz-tungsten-halogen (QTH) bulbs have been used as the main dental light-curing unit (LCU) for photopolymerization. These LCUs generate relatively broad spectra of wavelengths, usually between 370 and 520 nm<sup>11</sup>. However, some factors may compromise the performance of QTH units, such as fluctuation in the line voltage, long-term degradation of the bulb and filter, contamination of the light guide, damage to the fiberoptic bundle as well as bulb overheating within the unit<sup>12,13</sup>. On the other hand, the use of light emitting diodes (LEDs) is increasingly popular among clinicians. LEDs consume little power and do not require filters to produce blue light<sup>12,14</sup>. The main difference in the emission radiation is the narrower spectrum of wavelengths of the LEDs, which is usually centered at 470 nm<sup>14</sup>.

Differences in the spectrum of LCU emission can have a major effect on the polymerization process. Adhesives usually contain different co-monomers from resin composites, and may also contain organic solvents, which can affect polymerization<sup>15</sup>. The proper degree of conversion (DC) of the adhesive is important to their performance<sup>16</sup>. Despite these differences, the influence of LCUs used for light-curing of adhesive systems on the marginal integrity of

restorations has seldom been evaluated. Moreover, the substrate where the adhesive was applied can also affect the marginal integrity of the restoration. Traditionally, the dental substrate was etched with phosphoric acid, followed by rinsing and application of the adhesive agent<sup>17</sup>. Later, simpler adhesives were introduced with the development of self-etching primers/adhesives, eliminating the previous conditioning, rinsing, and drying steps that were critical for the adhesion protocol. However, it has been proved that this simplification does not improve bonding performance<sup>18,19</sup>.

Thus, the aim of this study was to evaluate the effect of LCU and the adhesive system on the marginal integrity of composite restorations. The null hypotheses were that (I) the light-curing unit (LED or QTH); (II) the localization of restoration margin and (III) adhesive system (etch-and-rinse or self-etching) have no effect on the marginal adaptation of composite restorations.

## MATERIALS AND METHODS

One week after extraction (teeth were stored in 0.05% thymol saline solution at 4°C), forty sound bovine incisors were cleaned, polished, and examined under a light microscope (Eclipse E 600; Nikon, Shinagawa-ku, Tokyo, Japan) in order to exclude any with cracks. The teeth were stored in distilled water at 5°C for less than one month before the restorative procedure. Standard shaped Class V cavities (3x3 mm, and 2 mm of depth) were prepared using a carbide bur #169L (KG Sorensen Ind. Com. Ltda. – Barueri, SP, Brazil) on the buccal surface. Each preparation was designed so that the incisal margin was in enamel and the gingival margin was in dentin. Within these dimensions, the C-factor of the cavity was 3.7. The cavities were made with a water-cooled high-speed drill using a standard cavity preparation device. The preparations were performed by the same operator and a new bur was used for each of the five cavities.

The experimental design is represented in Fig. 1. The cavities were restored using a two-step etch-and-rinse (Single Bond 2 (SB), 3M ESPE, St. Paul, MN, USA) or a two-step self-etching (Clearfil SE Bond (CL), Kuraray, Osaka, Japan) adhesive. For SB groups, a 35% phosphoric acid gel (3M Scotchbond Etchant, 3M ESPE) was applied to the entire cavity for 15 s. The acid was rinsed off with water for 15 s and the excess water was removed with a

small damp cotton pellet. SB adhesive system was applied according to the manufacturer's instructions to all cavity walls, which were checked for a shiny surface. The adhesive layer was thinned with a directed low-pressure air stream and light-cured for 20s. For CL groups, the self-etching primer was applied to the cavities, left undisturbed for 20s and the solvents were evaporated with an air-syringe. The adhesive was then applied, spread gently with an air-syringe and light-cured for 20s.

The cavities were restored with a microhybrid resin composite (Filtek Z-250, 3M ESPE, St. Paul, MN, USA), filled in one (bulk) increment of 2mm and light-cured for 20 seconds. The light-curing procedures were performed with QTH Optilux 501 (Demetron Kerr, Danbury, USA) or LED Radium-Cal (SDI, Bayswater, Victoria, Australia) devices. The light-curing tips available from manufacturers were used to simulate a clinical situation, despite the differences in light emission. The same light-curing unit was used on each cavity. All restored cavities were stored in distilled water at 37°C for 24h and, after this, polished

with flexible aluminum oxide disks (Sof-Lex Pop-on®, 3M ESPE, St. Paul, MN, USA) under a water spray. Impressions of restorations were taken using a polyvinyl siloxane impression material (Express, 3M ESPE, St. Paul, MN, USA) and replicas were made with epoxy resin (Epoxide, Buehler Ltd, Lake Bluff, IL). The replicas were mounted on aluminum stubs, gold sputter-coated (SCD 050, Baltec, Vaduz, Liechtenstein) and examined by scanning electron microscopy - SEM (JSM-5600LV, JEOL, Tokyo, Japan). The enamel and gingival margins were divided into three regions each for SEM analysis. The margins were analyzed under SEM at x500 magnification. The maximum length of marginal gap of each region was recorded in µm.

A nonparametric statistical analysis was performed because the gap data were non-normally distributed. The main effects evaluated were: adhesive system (SB or CL), LCU (QTH or LED) and substrate (enamel or dentin). The Mann-Whitney test was used to compare the adhesive systems at each level of LCU/substrate, and also to compare the LCUs at each level of adhesive system/substrate. The substrate factor was a paired data, thus it was compared at each level of adhesive system/LCU by Wilcoxon test. The level of significance of all analyses was set at 5%.

## RESULTS

The mean gap measurements are shown in Table 1. Adhesive systems had similar mean gap measurement at the enamel margins when the restorations were light-cured with QTH ( $p=0.49$ ). The same behavior was observed for the dentin margins when the light-activation was performed with LED ( $p=0.16$ ). On the other hand, higher mean gap measurements were observed at the enamel margins for CL when the restorations were performed using LED ( $p=0.02$ ). In contrast, SB had higher values of gap measurements in dentin when the light-activation was performed with QTH ( $p=0.0025$ ). The LCU showed significant effect on margin seal of the same adhesive/substrate condition only for SB/enamel. QTH resulted mean gap measurements than LED in this condition. No significant difference was observed between substrates when CL was used (QTH –  $p=0.88$ ; LED –  $p=0.37$ ). However, SB presented significantly higher gap measurements in dentin (QTH –  $p=0.04$ ; LED –  $p=0.007$ ). Illustrative micrographs obtained of the marginal integrity of restorations are shown in Figs. 2 and 3.

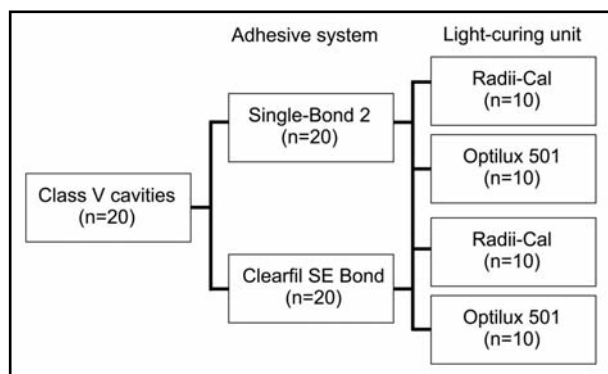

Fig. 1: Experimental design.

**Table 1: Mean gap measurements according to light-curing units and adhesive systems.**

Location of margin	Adhesive system	Light-curing unit	
		QTH	LED
Enamel	Single Bond 2	1.6 Ab $\beta$	0.1 Ba $\beta$
	Clearfil SE Bond	1.6 Aa $\beta$	1.4 Aa $\beta$
Dentin	Single Bond 2	8.6 Aa $\gamma$	5.4 Aa $\gamma$
	Clearfil SE Bond	1.9 Ba $\beta$	3.1 Aa $\beta$

Values followed by different letters indicate significant statistical difference. Capital letters compare adhesive systems within light source/substrate (Mann-Whitney,  $p<0.05$ ). Lowercase letters compare light sources within adhesive system/substrate (Mann-Whitney,  $p<0.05$ ). Greek letters compare substrates within adhesive system/light source (Wilcoxon,  $p<0.05$ ).

Fig. 2: (A) Intact margin in enamel obtained with Single Bond 2 light-cured with LED. (B) Presence of gap in enamel margin or restoration performed with Clearfil SE Bond and light-cured with LED. E-enamel, C-Composite.

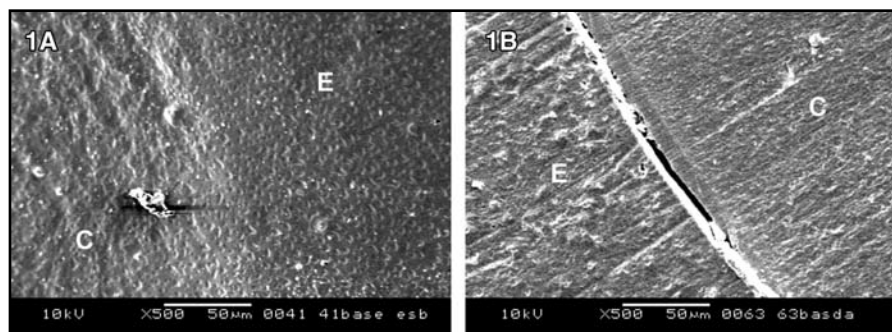
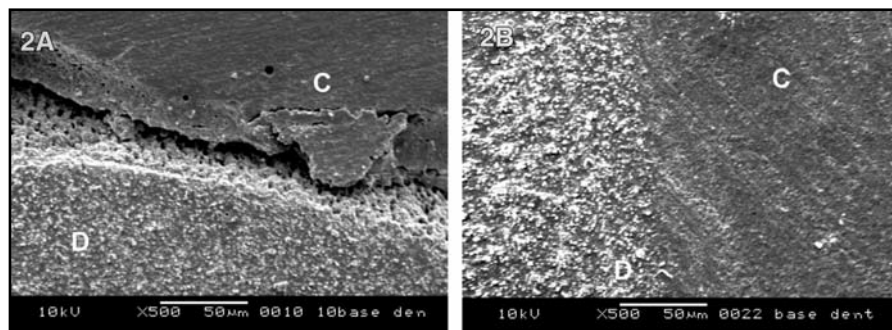

Fig. 3: (A) Presence of gap in dentin margin of restoration performed with Single Bond 2 and light-cured with QTH. (B) Absence of gap in dentin margin obtained with Clearfil SE Bond light-cured with QTH. E-enamel, C-Composite.



## DISCUSSION

In composite restorations, microleakage is often related to polymerization shrinkage that causes stress at the interface between the cavity wall and the restoration.<sup>1</sup> This stress can disrupt the bond and lead to the formation of gaps.<sup>8</sup> Thus, proper bonding of an adhesive to dental tissue contributes to preventing marginal microleakage.<sup>20,21</sup> In this study, both the light-curing unit, adhesive system type and location of margin had a significant effect on the marginal integrity of resin composite restorations. Thus, all null hypotheses were rejected.

The effect of the adhesive system on gap formation was dependent on margin location and the light-curing unit used for light-activation of the restoration. At enamel margins, restorations performed with CS had poorer marginal adaptation than those done with SB when light-cured with LED. A positive correlation was found between the formation of the gap and bond strength.<sup>19</sup> Thus, the bond strength of CS cured with LED to dentin can explain the results. CS contains the acidic monomer 10-MDP and has a pH of about 2. Self-etching adhesives with relatively high pH are unable to produce an acidic environment that will efficiently etch the enamel.<sup>19</sup>

Moreover, a lower DC of CS when light-cured with LED can also explain these results. A previous study using the same adhesives and light-curing units

demonstrated that CS has lower DC when light cured with Radium-Cal than with Optilux 501.<sup>15</sup> Despite the lower irradiance levels, the LED Radium Cal presents a narrow emission peak.<sup>15</sup> This peak is consistent with the absorption peak of camphorquinone, which is the photoinitiator used in both CS and SB. However, the peak of camphorquinone can be altered during the process of light-activation<sup>22</sup> and in the presence of organic solvent.<sup>23</sup> A poorer DC is related to lower bond strength, explaining the results of this study.<sup>24</sup> In contrast, SB had a higher DC when light-cured with Radium-Cal than Optilux 501.<sup>15</sup> This may explain the better performance of SB when light-cured with Radium-Cal.

At the dentin margin, CS had better marginal adaptation than SB when the restoration was performed with QTH. Both etch-and-rinse and self-etching adhesives have an adequate bond strength to dentin.<sup>19</sup> Due the lower mineral content, the relative low acidity of CS does not compromise the effectiveness of substrate etching. Thus, the mechanical properties are essential to the adequate behavior of the adhesive in the dentinal substrate.<sup>24</sup> A lower DC of SB light-cured with Optilux 501 than cured with Radium-Cal<sup>15</sup> may explain again the poorer marginal adaptation of restorations using this adhesive and light-cured with QTH. In contrast, QTH is more effective on polymerization of CS than LED.<sup>15</sup> A

higher DC results in improved mechanical properties and higher integrity of restoration margins. Good marginal sealing is essential for improving the longevity of resin composite restorations. A sealed margin prevents marginal discoloration and secondary caries, which are the main reasons for restoration replacements.<sup>1,25</sup> Class V cavities were chosen in this study due their cavity configuration factor, which prevents the resin composite from flowing during polymerization shrinkage. Moreover, these cavities frequently have gingival margins in dentin, posing an additional challenge to obtaining a proper marginal seal. The outcomes of the present study showed that the light-curing unit, adhesive system and margin location have an important effect on marginal adaptation of composite restorations. Considering that these factors are dependent on each other, the choice of light-curing unit must be based on the adhesive system used in the restoration.

#### ACKNOWLEDGEMENTS

This study was supported by the Brazilian National Research Council (CNPq) grant #150935/2005-6.

#### REFERENCES

1. Heintze SD. Systematic reviews: I. The correlation between laboratory tests on marginal quality and bond strength. II. The correlation between marginal quality and clinical outcome. *J Adhes Dent* 2007;9:77-106.
2. Bernrado M, Luis H, Martin MD, Leroux BG, Rue T, Leitão J, DeRouen T. Survival and reasons for failure of amalgam versus composite posterior restorations in a randomized clinical trial. *J Am Dent Assoc* 2007;138:775-783.
3. Sarret DC. Prediction of clinical outcomes of a restoration based on in vivo marginal quality evaluation. *J Adhes Dent* 2007;9:117-120.
4. Van Ende A, De Munck J, Mine A, Lambrechts P, Van Meerbeek B. Does a low-shrinking composite induce less stress at the adhesive interface? *Dent Mater* 2010;26:215-222.
5. Banomyong D, Palamara JE, Messer HH, Burrow MF. Sealing ability of occlusal resin composite restoration using four restorative procedures. *Eur J Oral Sci* 2008;116:571-578.
6. Ye Q, Wang Y, Williams K, Spencer P. Characterization of photopolymerization of dentin adhesives as a function of light source and irradiance. *J Biomed Mater Res B Appl Biomater* 2007;80:440-446.
7. Spinell T, Schedle A, Watts DC. Polymerization shrinkage kinetics of dimethacrylate resin-cements. *Dent Mater* 2009; 25:1058-1066.

#### CONCLUSION

Based on the results of the present study, it can be concluded that:

At enamel margins, Single Bond 2 had lower gaps when light-cured with LED, while the light-curing unit did not affect gap formation when Clearfil SE Bond was used.

When the restorations were performed with LED, Single Bond 2 resulted in better marginal adaptation of the restorations at enamel margins than Clearfil SE Bond. There was no difference between the adhesives when the light-curing was performed with QTH.

At dentin margins, Clearfil SE Bond provided better sealing than Single Bond 2 when QTH was used for light-activation, while the adhesives had similar behavior with LED.

Light-curing units did not affect marginal adaptation to dentin margin for any adhesive system.

#### CORRESPONDENCE

André Luis Faria-e-Silva  
Departamento de Odontologia  
Centro de Ciências Biológicas e da Saúde  
Universidade Federal de Sergipe  
Rua Cláudio Batista, s/n – Sanatório  
49060-100 Aracaju-SE, Brazil  
andrelsilva@hotmail.com

8. Braga RR, Ballester RY, Ferracane JL. Factors involved in the development of polymerization shrinkage stress in resin-composites: a systematic review. *Dent Mater* 2005;21:962-970.
9. Papadogiannis D, Kakaboura A, Palaghias G, Eliades G. Setting characteristics and cavity adaptation of low-shrinking resin composites. *Dent Mater* 2009; 25:1509-1516.
10. Takahashi H, Finger WJ, Wegner K, Utterodt A, Komatsu M, Wostmann B, Balkenhol M. Factors influencing marginal cavity adaptation of nanofiller containing resin composite restorations. *Dent Mater* 2010;26:1166-1175.
11. Nomoto R, McCabe JF, Hirano S. Comparison of halogen, plasma and LED curing units. *Oper Dent* 2004; 29:287-294.
12. Jimenez-Planas A, Martin J, Abalos C, Lamas R. Developments in polymerization lamps. *Quintessence Int* 2008;39:e74-84.
13. Strydom C. Dental curing lights-maintenance of visible light curing units. *SADJ* 2002;57:227-233.
14. Leonard DL, Charlton DG, Roberts HW, Cohen ME. Polymerization efficiency of LED curing lights. *J Esthet Restor Dent* 2002;14:286-295.
15. Faria e Silva AL, Lima AF, Moraes RR, Piva E, Martins LR. Degree of conversion of etch-and-rinse and self-etch adhesives light-cured using QTH or LED. *Oper Dent* 2010; 35:649-654.
16. Reis A, Ferreira SQ, Costa TR, Klein-Júnior CA, Meier MM, Loguercio AD. Effects of increased exposure times

- of simplified etch-and-rinse adhesives on the degradation of resin-dentin bonds and quality of the polymer network. *Eur J Oral Sci.* 2010;118:502-509.
17. Marshall SJ, Bayne SC, Baier R, Tomsia AP, Marshall GW. A review of adhesion science. *Dent Mater* 2010;26: 11-16.
  18. Peumans M, Kanumilli P, De Munck J, Van Landuyt K, Lambrechts P, Van Meerbeek B. Clinical effectiveness of contemporary adhesives: a systematic review of current clinical trials. *Dent Mater* 2005;21:864-881.
  19. De Munck J, Van Landuyt K, Peumans M, Poitevin A, Lambrechts P, Braem M, Van Meerbeek B. A critical review of the durability of adhesion to tooth tissue: methods and results. *J Dent Res* 2005;84:118-132.
  20. Khosravi K, Ataei E, Mousavi M, Khodaeian N. Effect of phosphoric acid etching of enamel margins on the microleakage of a simplified all-in-one and a self-etch adhesive system. *Oper Dent* 2009;34:531-536.
  21. Moldes VL, Capp CI, Navarro RS, Matos AB, Youssef MN, Cassoni A. In vitro microleakage of composite restorations prepared by Er:YAG/Er,Cr:YSGG lasers and conventional drills associated with two adhesive systems. *J Adhes Dent* 2009;11:221-229.
  22. Chen YC, Ferracane JL, Prah SA. Quantum yield of conversion of the photoinitiator camphorquinone. *Dent Mater* 2007;23:655-664.
  23. Moss L, Rueggeberg FA, Stansbury JW. Effect of solvent type on absorption profile of camphoroquinone. *J Dent Res* 2002;81 [special issue A:A-255–A-255].
  24. Kanehira M, Finger WJ, Hoffmann M, Endo T, Komatsu M. Relationship between degree of polymerization and enamel bonding strength with self-etching adhesives. *J Adhes Dent* 2006;8:211-216.
  25. Asghar S, Ali A, Rashid S, Hussain T. Replacement of resin-based composite restorations in permanent teeth. *J Coll Physicians Surg Pak* 2010;20:639-643.